



www.polyskid.com
P. O. Drawer 349, Monticello, GA. 31064
Phone: 800-542-7659
Fax: 706-468-2881
E-Mail: polytech@polyskid.com

INSTALLATION OF THE 1/4" POLY AIR DUCT LINER KIT for the KMC WIDE BODY 4 and 6 ROW PEANUT COMBINE

PLEASE READ THE ENTIRE INSTRUCTION SHEET
BEFORE STARTING INSTALLATION

PLEASE REFER TO THE OPERATORS MANUAL FOR YOUR
SPECIFIC COMBINE FOR PERTINENT SAFETY PRECAUTIONS

1. Compare the contents with the following parts list to confirm that you have received the correct panels and associated hardware.

KIT #: PCKK001 (Standard tank duct)

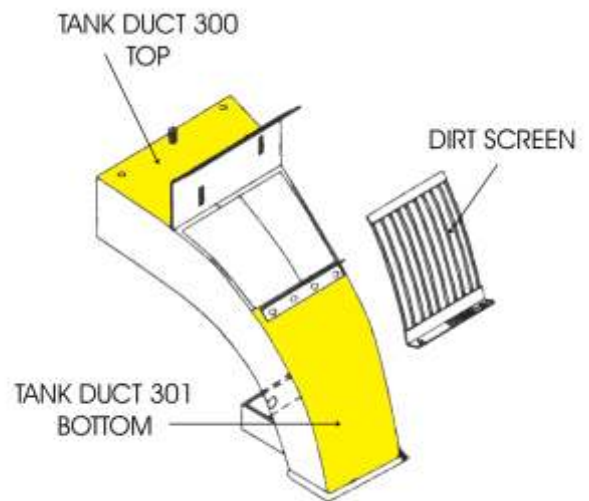
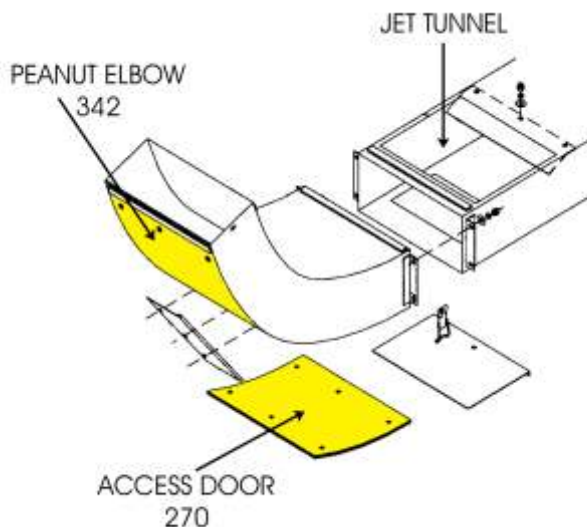

PCKH001
Hardware



2. Remove ducts from combine.
3. Remove existing liners and thoroughly clean ducts.
4. Starting with the access door, align the PCKL270 liner with the direction of flow and position the “in- put” end flush with the edge of the door as illustrated below.
5. Secure the liner with the 1/4-20 x 3/4 elevator bolts, flat washers, and nylon inserted lock nuts supplied.

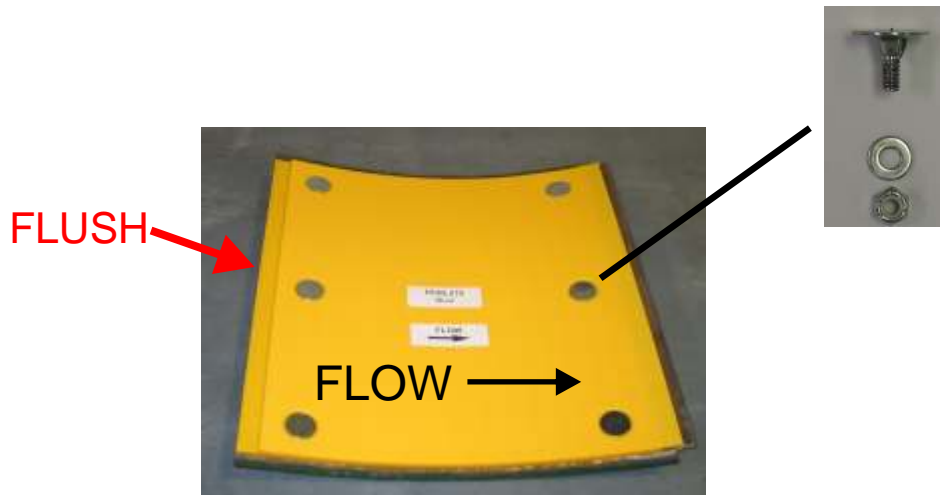

6. Tighten the bolts to firmly seat the head of the bolt....



...then loosen the nut
3/4 to 1 turn.

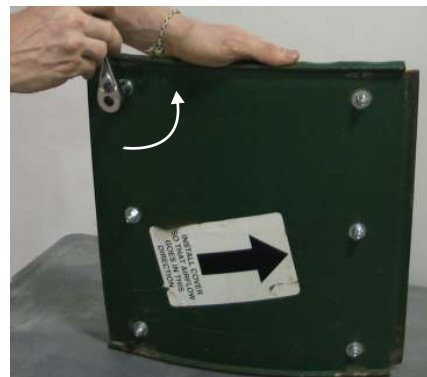

7. Install the remaining liners using the same procedures as described in Step 5 and Step 6.

8. When installing the elbow liner PCKL342, the factory metal strip is eliminated.

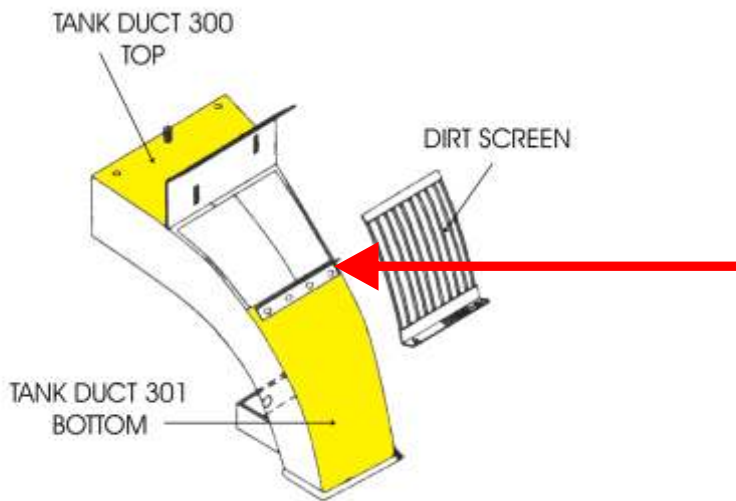
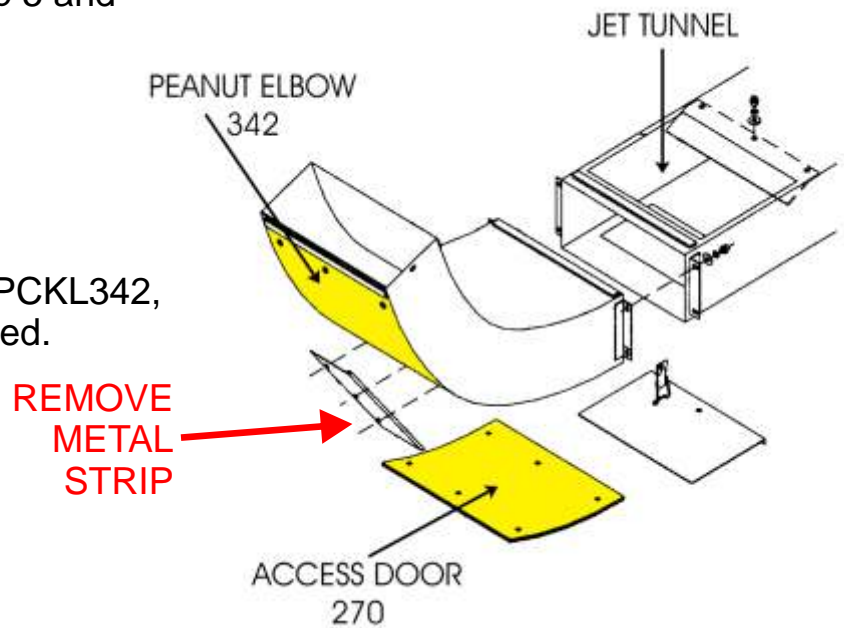

9. Longer elevator bolts (4ea) have been supplied for the upper end of the TANK DUCT BOTTOM liner.



Questions or comments call 1-800-542-7659